



# Installation Instructions

## CONTENTS

	Page
<b>GENERAL</b> .....	1
<b>SAFETY CONSIDERATIONS</b> .....	1,2
<b>INSTALLATION</b> .....	2-16
<b>Location</b> .....	2
<b>Step 1 — Inspect Shipment</b> .....	2
<b>Step 2 — Position the Unit</b> .....	2
<b>Step 3 — Place the Unit</b> .....	7
<b>Step 4 — Check Compressor Mounting</b> .....	7
<b>Step 5 — Make Piping Connections</b> .....	7
• 30MPA SYSTEM CONDENSER	
• 30MPW CONDENSER DESCRIPTION	
• 30MPW CONDENSER	
• EVAPORATOR DESCRIPTION	
• EVAPORATOR PIPING	
• AIR SEPARATION	
<b>Step 6 — Fill the Chilled Water Loop</b> .....	13
• WATER SYSTEM CLEANING	
• FILLING THE SYSTEM	
<b>Step 7 — Make Electrical Connections</b> .....	14
• FLOW SWITCH	
• CONTROL BOX, POWER SECTION	
• CONTROL BOX, CONTROLS SECTION	
• CONTROL BOX, FIELD CONTROL WIRING SECTION	
• UNBALANCED 3-PHASE SUPPLY VOLTAGE	

## GENERAL

These installation instructions cover the 30MPA, MPW units with *ComfortLink* controls. The 30MPA units are condenserless units and the 30MPW units are all fluid cooled.

## SAFETY CONSIDERATIONS

Installing, starting up, and servicing this equipment (Fig. 1 and 2) can be hazardous due to system pressures, electrical components, and equipment location (roofs, elevated structures, etc.). Model number structure is shown in Fig. 3.

Only trained, qualified installers and service technicians should install, start up, and service this equipment.

When working on the equipment, observe precautions in the literature and on tags, stickers, and labels attached to the equipment.

- Follow all safety codes.
- Wear safety glasses and work gloves.
- Use care in handling, rigging, and setting bulky equipment.

### ⚠ WARNING

Electrical shock can cause personal injury and death. Shut off all power to this equipment during installation. There may be more than one disconnect switch. Tag all disconnect locations to alert others not to restore power until work is completed.

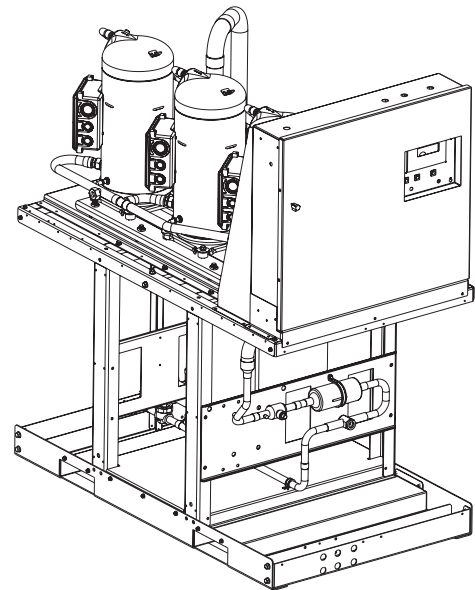

**Fig. 1 — 30MPA Unit**

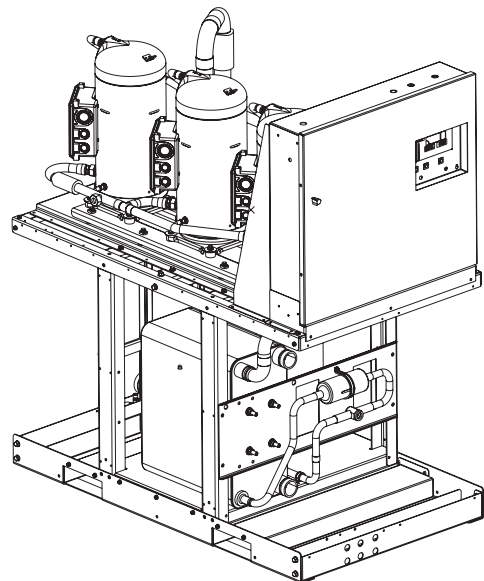

**Fig. 2 — 30MPW Unit**

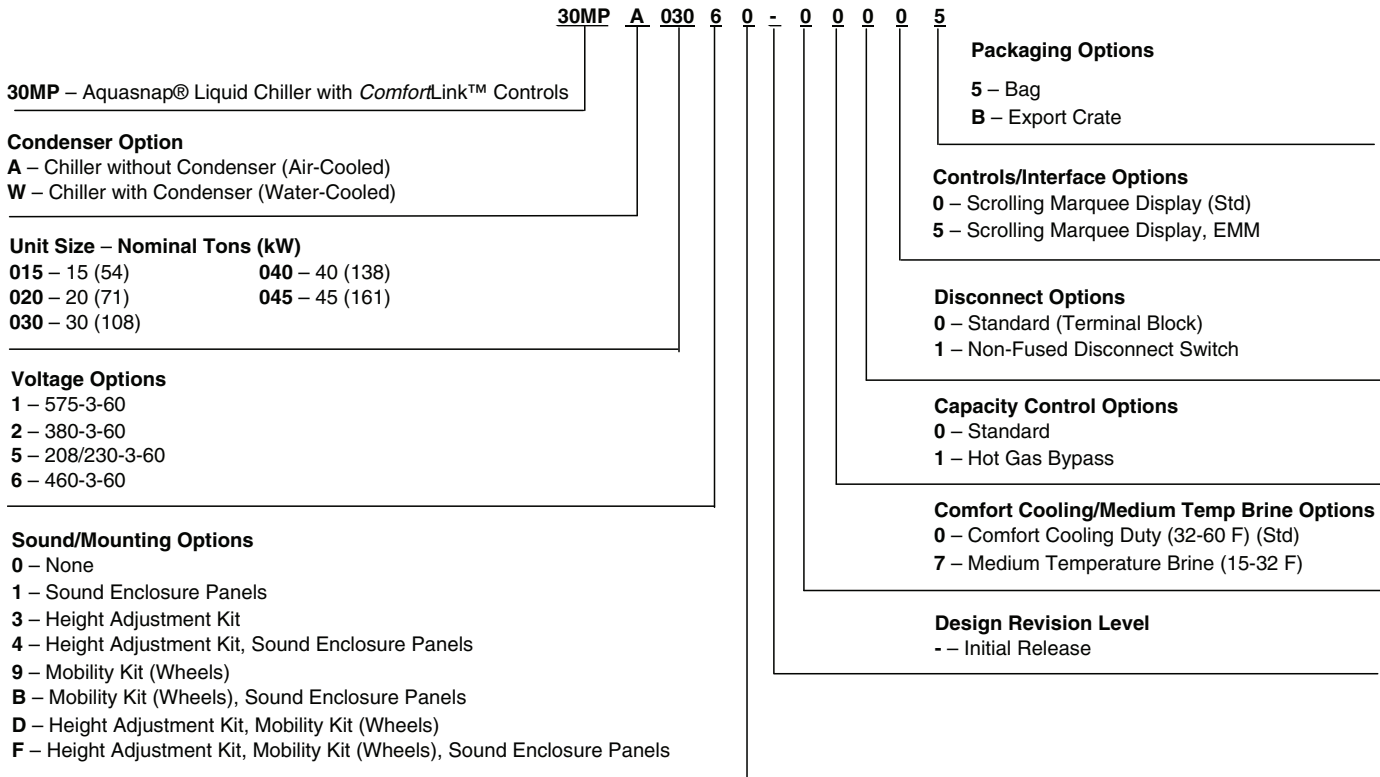

**LEGEND**

- EMM** — Energy Management Module
- LON** — Local Operating Network
- UPC** — Unitary Protocol Controller

**Fig. 3 — 30MP Model Number Nomenclature**

**INSTALLATION**

**Location** — Do not store units in an area exposed to weather because of sensitive control mechanisms and electronic devices. Locate unit indoors. See Fig. 4 and 5 for unit dimensional details.

When considering location, consult National Electrical Code (NEC) and local code requirements. Allow sufficient space for wiring, piping, and service. Install unit in an area where it will not be exposed to ambient temperatures below 50 F (10 C).

Allow 36 in. (914 mm) in front of the unit for control box access door. Additional clearance may be required per local codes. Prior to installation determine which direction compressor will be removed, and leave 3 to 4 ft (914 to 1219 mm) clearance for removal.

On all units leave 3 ft (0.9 m) of clearance behind the unit to make water/brine connections to the evaporator, accessing the TXV (thermostatic expansion valve), fluid thermistors, and proof of flow switch.

On all units, leave 2 ft (610 mm) on one side for making refrigeration connections (30MPA) or fluid connections (30MPW) to condenser. See Fig. 4 and 5.

The floor must be strong enough to support the unit operating weight (see Tables 1A and 1B and Fig. 4-6). If necessary, add a supporting structure (steel beams or reinforced concrete slabs) to the floor to transfer weight to nearest beams.

Additional weight of factory-installed sound enclosure option is 75 lb (34 kg).

**⚠ CAUTION**

Be sure interconnecting piping and electrical conduits are suspended freely, and are not in contact with any adjacent walls. Be sure unit capillaries are not rubbing against anything. Damage to unit or walls may result.

**Step 1 — Inspect Shipment** — Inspect unit for damage or missing parts. If damaged, or if shipment is incomplete, file a claim immediately with the shipping company.

**⚠ CAUTION**

Unit is top heavy. Unit may tip if handled without care. Damage to unit or injury may result.

**Step 2 — Position the Unit** — The unit may be moved by means of rollers under the rails or a forklift truck.

If accessory mobility kit is to be used, install this accessory after bringing unit into building and before moving the unit to its final location per installation instructions provided with the accessory. The factory-installed mobility kit option consists of 4 swivel-type wheels that are field-mounted to the legs of the unit. See Fig. 7.

NOTE: The wheels are equipped with a thumb-screw brake.

UNIT	OPERATING WEIGHT (lb)	A	B	C	D	E	F	NO. OF COMPRESSORS
30MPA015	626 (284 kg)	17.80 (452 mm)	25.10 (638 mm)	31.49 (800 mm)	5.54 (141 mm)	6.44 (164 mm)	18.50 (470 mm)	2
30MPA020	635 (288 kg)	17.60 (447 mm)	25.20 (640 mm)	31.39 (797 mm)	5.87 (149 mm)	11.12 (282 mm)	17.95 (456 mm)	3
30MPA030	722 (327 kg)	17.00 (432 mm)	26.00 (660 mm)	30.69 (780 mm)	5.99 (152 mm)	11.00 (279 mm)	17.72 (450 mm)	3
30MPA040	913 (414 kg)	17.50 (445 mm)	25.90 (658 mm)	33.50 (851 mm)	5.99 (152 mm)	11.00 (279 mm)	17.72 (450 mm)	3
30MPA045	934 (424 kg)	17.40 (442 mm)	26.00 (660 mm)	33.49 (851 mm)	5.99 (152 mm)	11.00 (279 mm)	17.72 (450 mm)	3

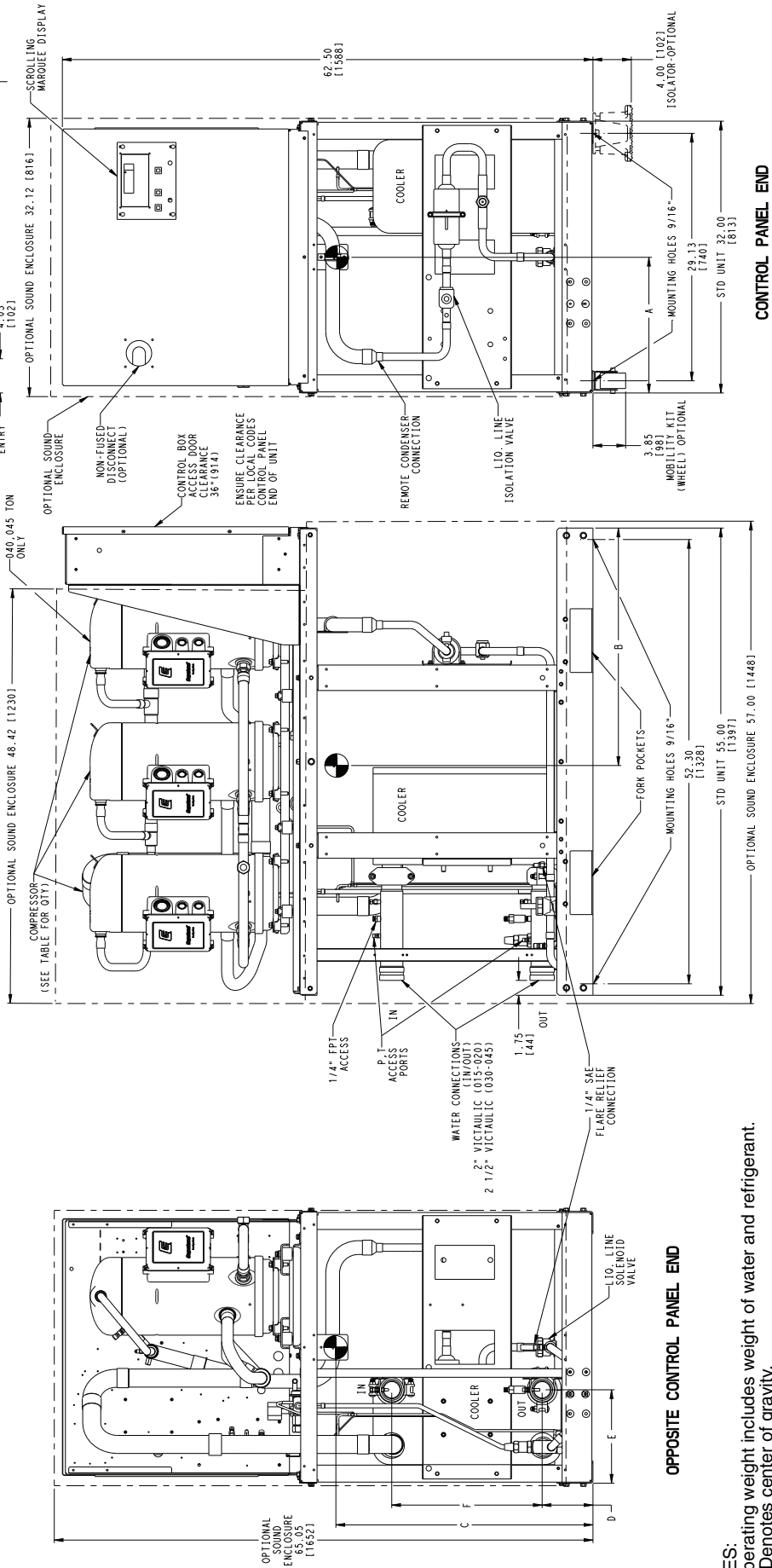

- NOTES:
- Operating weight includes weight of water and refrigerant.
  - Denotes center of gravity.
  - Dimensions are shown in inches. Dimensions in [ ] are in millimeters.
  - Allow 36-in. (914 mm) clearance on control panel end, opposite control panel end and above the unit. All clearances must be in accordance with local codes.
  - Denotes accessory or factory-installed option.

Fig. 4 — Dimensions — 30MPA015-045 Units

UNIT	OPERATING WEIGHT (lb)	A	B	C	D	E	F	G	H	J	NO. OF COMPRESSORS
30MPW015	680 (308 kg)	18.50 (470mm)	24.80 (630 mm)	30.53 (775 mm)	5.54 (141 mm)	6.44 (164 mm)	18.50 (470 mm)	5.54 (141 mm)	6.44 (164 mm)	18.50 (470 mm)	2
30MPW020	704 (319 kg)	18.20 (462 mm)	25.20 (640 mm)	30.20 (767 mm)	5.87 (149 mm)	11.12 (282 mm)	16.89 (429 mm)	5.87 (149 mm)	11.12 (282 mm)	17.95 (456 mm)	2
30MPW030	862 (391 kg)	18.60 (472 mm)	25.10 (638 mm)	30.96 (786 mm)	5.87 (149 mm)	11.12 (282 mm)	17.95 (456 mm)	5.99 (152 mm)	11.00 (279 mm)	17.72 (450 mm)	3
30MPW040	1099 (499 kg)	18.90 (480 mm)	24.90 (632 mm)	30.22 (768 mm)							
30MPW045	1190 (540 kg)										

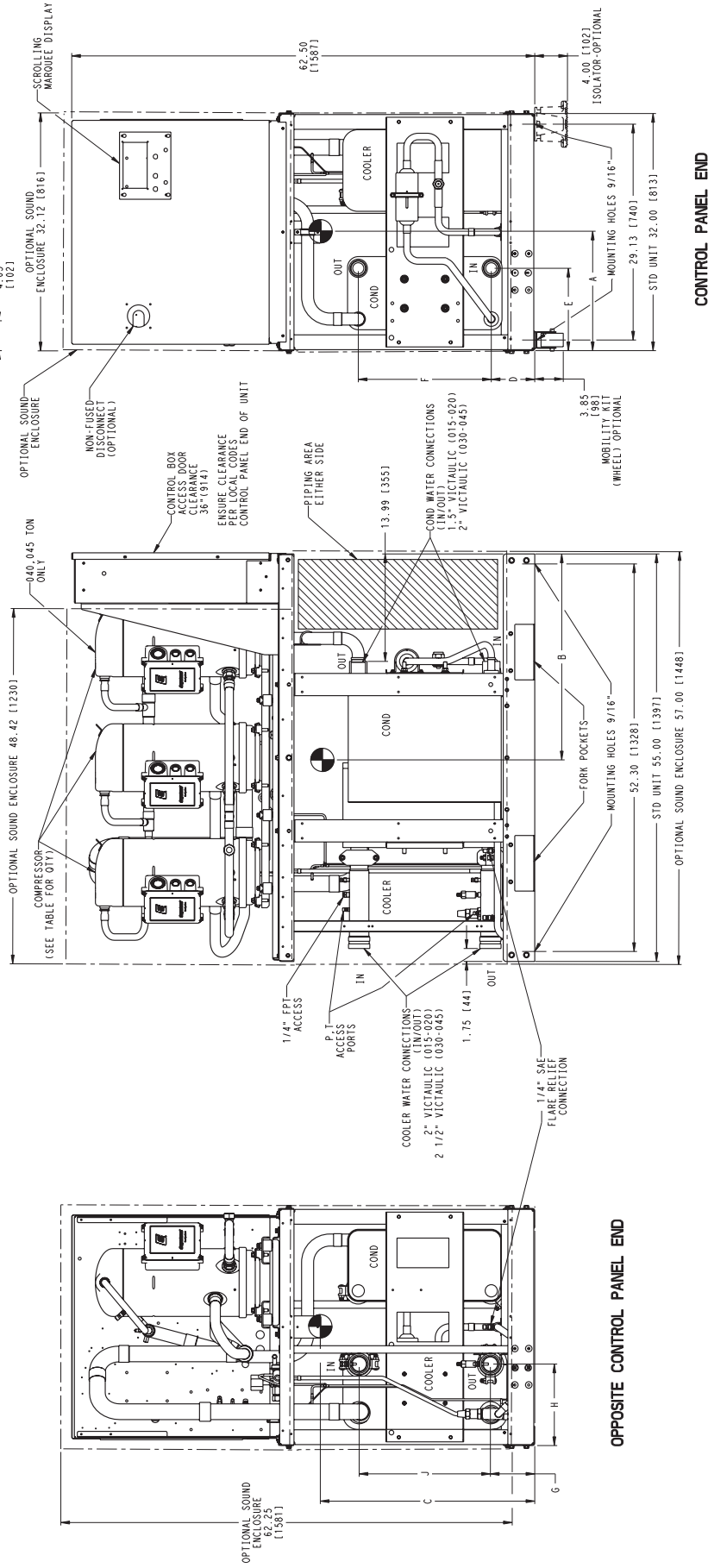

- NOTES:**
1. Operating weight includes weight of water and refrigerant.
  2. Ⓞ Denotes center of gravity.
  3. Dimensions are shown in inches. Dimensions in [ ] are in millimeters.
  4. Allow 36-in. (914 mm) clearance on control panel end, opposite control panel end and above the unit. All clearances must be in accordance with local codes.
  5. --- Denotes accessory or factory-installed option.

→ Fig. 5 — Dimensions — 30MPW015-045 Units

**Table 1A — 30MPA Air-Cooled and 30MPW Liquid-Cooled Units — English**

<b>UNIT 30MPA,MPW</b>	<b>015</b>	<b>020</b>	<b>030</b>	<b>040</b>	<b>045</b>
<b>NOMINAL TONS</b>	15	20	30	40	45
<b>OPERATING WT (lb)</b>					
<b>MPA</b>	626	635	722	913	934
<b>MPW</b>	680	704	862	1099	1190
<b>REFRIGERANT (lb)</b>			<b>R-410A</b>		
<b>MPA</b>	—	—	—	—	—
<b>MPW</b>	11.6	15.2	23.1	29.4	34.4
<b>COMPRESSOR</b>			<b>Scroll, Hermetic</b>		
<b>Quantity</b>	2	2	2	3	3
<b>Speed (rpm)</b>	3500	3500	3500	3500	3500
<b>Compressor Nominal Tons</b>	7.5	10	15	13	15
<b>Oil Charge (pt)</b>	10.6	13.8	13.8	20.6	20.6
<b>Capacity Control — Standard</b>					
<b>No. of Steps</b>	2	2	2	3	3
<b>Minimum Step Capacity (%)</b>	50	50	50	33	33
<b>Capacity Control — Optional Hot Gas Bypass</b>					
<b>No. of Steps</b>	3	3	3	4	4
<b>Minimum Step Capacity (%)</b>	18	25	34	21	22
<b>EVAPORATOR</b>					
<b>Weight (lb, empty)</b>	27.5	40.3	91.8	122.3	128.3
<b>Net Fluid Volume (gal.)</b>	0.8	1.2	2.4	3.2	3.4
<b>Maximum Refrigerant Pressure (psig)</b>	650	650	650	650	650
<b>Maximum Fluid-Side Pressure (psig)</b>	300	300	300	300	300
<b>Water Connections (in.)</b>					
<b>Inlet and Outlet (Victualic)</b>	2	2	2 <sup>1/2</sup>	2 <sup>1/2</sup>	2 <sup>1/2</sup>
<b>Drain (NPT)</b>	1/2	1/2	1/2	1/2	1/2
<b>CONDENSER (30MPW Only)</b>					
<b>Weight (lb, empty)</b>	34.9	43.6	104.6	136.7	188.3
<b>Net Fluid Volume (gal.)</b>	1.2	1.6	2.9	4.1	5.9
<b>Maximum Refrigerant Pressure (psig)</b>	650	650	650	650	650
<b>Maximum Fluid-Side Pressure (psig)</b>	300	300	300	300	300
<b>Water Connections (in.)</b>					
<b>Inlet and Outlet (Victualic)</b>	2	2	2 <sup>1/2</sup>	2 <sup>1/2</sup>	2 <sup>1/2</sup>
<b>CHASSIS DIMENSIONS (in.)</b>					
<b>Length</b>	55	55	55	55	55
<b>Width</b>	32	32	32	32	32
<b>Height</b>	63	63	63	63	63
<b>MINIMUM SYSTEM FLUID VOLUME (gal. per Ton)</b>					
<b>Normal Air Conditioning</b>					
<b>Standard</b>	6	6	6	4	4
<b>Optional Hot Gas Bypass</b>	4	4	4	3	3
<b>Low Outdoor Ambient Cooling Operation (30MPA Units)</b>					
<b>Standard</b>	10	10	10	8	8
<b>Optional Hot Gas Bypass</b>	7	7	7	6	6
<b>CAPACITY STEPS</b>					
<b>Step 1</b>	100%	100%	100%	100%	100%
<b>Step 2</b>	50%	50%	50%	67%	67%
<b>Step 3</b>	18%*	25%*	34%*	33%	33%
<b>Step 4</b>	—	—	—	21%*	22%*
<b>MINIMUM FLOW RATES (gpm)</b>					
<b>Evaporator</b>	22	28	43	55	64
<b>Condenser</b>	22	28	43	55	64
<b>MAXIMUM FLOW RATES (gpm)</b>					
<b>Evaporator</b>	74	97	148	188	220
<b>Condenser</b>	74	97	148	188	220

\* With optional hot gas bypass.

**NOTES:**

1. Operating weight includes refrigerant operating charge and weight of fluid in the heat exchangers.
2. 30MPW units are shipped with full operating charge.

**Table 1B — 30MPA Air-Cooled and 30MPW Liquid-Cooled Units — SI**

<b>UNIT 30MPA,MPW</b>	<b>015</b>	<b>020</b>	<b>030</b>	<b>040</b>	<b>045</b>
<b>NOMINAL KW</b>	54	71	108	138	161
<b>OPERATING WT (kg)</b>					
MPA	284	288	327	414	424
MPW	308	319	391	499	540
<b>REFRIGERANT (kg)</b>			R-410A		
MPA	—	—	—	—	—
MPW	5.2	6.9	10.5	13.3	15.6
<b>COMPRESSOR</b>			Scroll, Hermetic		
Quantity	2	2	2	3	3
Speed (r/s)	58	58	58	58	58
Compressor Nominal kW	26	35	53	45	53
Oil Charge (L)	5.0	6.5	6.5	9.8	9.8
Capacity Control — Standard					
No. of Steps	2	2	2	3	3
Minimum Step Capacity (%)	50	50	50	33	33
Capacity Control — Optional Hot Gas Bypass					
No. of Steps	3	3	3	4	4
Minimum Step Capacity (%)	18	25	34	21	22
<b>EVAPORATOR</b>					
Weight (kg, empty)	12.5	18.3	41.6	55.5	58.2
Net Fluid Volume (L)	2.9	4.6	8.9	12.0	13.0
Maximum Refrigerant Pressure (kPa)	4482	4482	4482	4482	4482
Maximum Fluid-Side Pressure (kPa)	2068	2068	2068	2068	2068
Water Connections (in.)					
Inlet and Outlet (Victualic)	2	2	2 <sup>1/2</sup>	2 <sup>1/2</sup>	2 <sup>1/2</sup>
Drain (NPT)	1/2	1/2	1/2	1/2	1/2
<b>CONDENSER (30MPW)</b>					
Weight (kg, empty)	15.8	19.8	47.4	62.0	85.4
Net Fluid Volume (L)	4.5	5.9	11.1	15.4	22.4
Maximum Refrigerant Pressure (kPa)	4482	4482	4482	4482	4482
Maximum Fluid-Side Pressure (kPa)	2068	2068	2068	2068	2068
Water Connections (in.)					
Inlet and Outlet (Victualic)	1 <sup>1/2</sup>	1 <sup>1/2</sup>	2	2	2
<b>CHASSIS DIMENSIONS (mm)</b>					
Length	1397	1397	1397	1397	1397
Width	813	813	813	813	813
Height	1600	1600	1600	1600	1600
<b>MINIMUM SYSTEM FLUID VOLUME (L per kW)</b>					
Normal Air Conditioning					
Standard	23	23	23	15	15
Optional Hot Gas Bypass	15	15	15	11	11
Low Outdoor Ambient Cooling Operation (30MPA Units)					
Standard	38	38	38	30	30
Optional Hot Gas Bypass	25	25	25	23	23
<b>CAPACITY STEPS</b>					
Step 1	100%	100%	100%	100%	100%
Step 2	50%	50%	50%	67%	67%
Step 3	18%*	25%*	34%*	33%	33%
Step 4	—	—	—	21%*	22%*
<b>MINIMUM FLOW RATES (L/s)</b>					
Evaporator	1.4	1.8	2.7	3.5	4.0
Condenser	1.4	1.8	2.7	3.5	4.0
<b>MAXIMUM FLOW RATES (L/s)</b>					
Evaporator	4.7	6.1	9.3	11.9	13.9
Condenser	4.7	6.1	9.3	11.9	13.9

\* With optional hot gas bypass.

**NOTES:**

1. Operating weight includes refrigerant operating charge and weight of fluid in the heat exchangers.
2. 30MPW units are shipped with full operating charge.

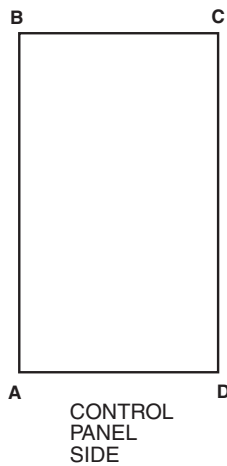

WEIGHT DISTRIBUTION AT EACH MOUNTING HOLE — Lb (kg)

UNIT 30MP	MOUNTING HOLE			
	A	B	C	D
A015		156 (71)		
A020		159 (72)		
A030		181 (82)		
A040		228 (104)		
A045		234 (106)		
W015		170 (77)		
W020		176 (80)		
W030		216 (98)		
W040		275 (125)		
W045		298 (135)		

Fig. 6 — Mounting Hole Weight Distribution

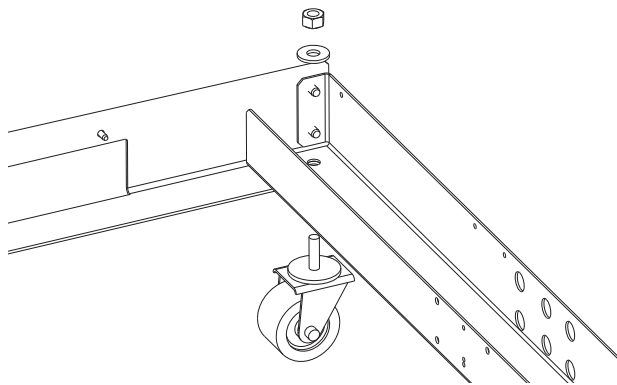

Fig. 7 — Mobility Kit

### Step 3 — Place the Unit

NOTE: *These units are not suitable for unprotected outdoor use.*

Carrier recommends that these units be located in the basement or on the ground floor. However, if it is necessary to locate the unit on an upper floor, be sure the structure has been designed to support the unit weight. If necessary, add structural support to floor. Also, be sure the surface for installation is level. Refer to Fig. 4 and 5 for space requirements and weight distribution.

Only electrical power connections, water connections for condenser, fluid connections for evaporator, and strainer installation are required for 30MPW installation. Installation of

30MPA units varies only in field piping required for the remote condenser.

When the unit is in its final position, remove the packaging and remove the mobility kit wheels (if equipped). Remove  $\frac{3}{8}$ -in. wheel nuts to remove wheels from unit legs. Level the unit (using a level), and bolt the unit to the floor or pad.

If unit is to be mounted on unit external vibration isolators, follow the mounting instructions included with the accessory vibration isolator.

If unit has accessory leveling kit installed, follow the instructions provided with the accessory to make sure unit is level and in the correct position.

**Step 4 — Check Compressor Mounting** — As shipped, units with two compressors are held down with 6 bolts through rubber grommets. All units with three compressors are held down with 8 bolts per pair through grommets. After unit is installed, verify mounting bolt torque 7 to 10 ft-lb (9 to 14 Nm).

**Step 5 — Make Piping Connections** — See Fig. 8 and 9 for typical piping applications.

**30MPA SYSTEM CONDENSER** — For detailed condenser piping installation instructions for 30MPA systems, refer to separate instructions packaged with the remote condenser units.

Condenser refrigerant piping for 30MPA units should be sized to minimize the amount of refrigerant required.

The 30MPA units that use air-cooled evaporative condensers must have adequate means for head pressure control when operating below 60 F (15.6 C).

Carrier recommends that a field-supplied pressure relief device be installed in each discharge line of 30MPA units. Most local codes require the discharge line relief valve to be vented directly to the outdoors. The vent **must not** be smaller than the discharge line relief valve outlet.

**30MPW CONDENSER DESCRIPTION** — All 30MPW units use a brazed-plate heat-exchanger-type condenser. These heat exchangers are made of embossed plates of acid-resistant stainless steel. Every other plate is reversed so that the ridges of the herringbone pattern intersect one another on adjacent plates, forming a lattice of contact points. These plates are vacuum-brazed together to form a compact and pressure-resistant heat exchanger.

After brazing, the impressions in the plates form 2 separate systems of channels where the refrigerant and water flows are counterflow. The number of plates varies depending on unit tonnage. The condensers provide approximately 10° to 12° F (6° to 8° C) liquid subcooling at the standard Air Conditioning, Heating and Refrigeration Institute (AHRI) rating condition.

**30MPW CONDENSER** — When facing the unit control box, the condenser is the uninsulated heat exchanger located on the left-hand side. The water connections are on the right-hand side of the heat exchanger with the LIQUID-IN connection at the bottom, and the LIQUID-OUT connection at the top.

A strainer with a minimum of 40 mesh **must** be installed within 10 ft (3 m) of the condenser water inlet to prevent debris from clogging or damaging the heat exchanger. The strainer is required for operation and is available as an accessory.

To install the victaulic coupling (see Fig. 10):

1. Lubricate the gasket lips and stretch the gasket over the end of the heat exchanger coupling. Avoid twisting the gasket when installing.
2. Bring the pipe and heat exchanger coupling ends together into alignment. Slide the gasket so that it is centered over the ends. Apply a light film of lubricant to the gasket, or to the outside diameter of the pipe. Avoid twisting the gasket during installation.



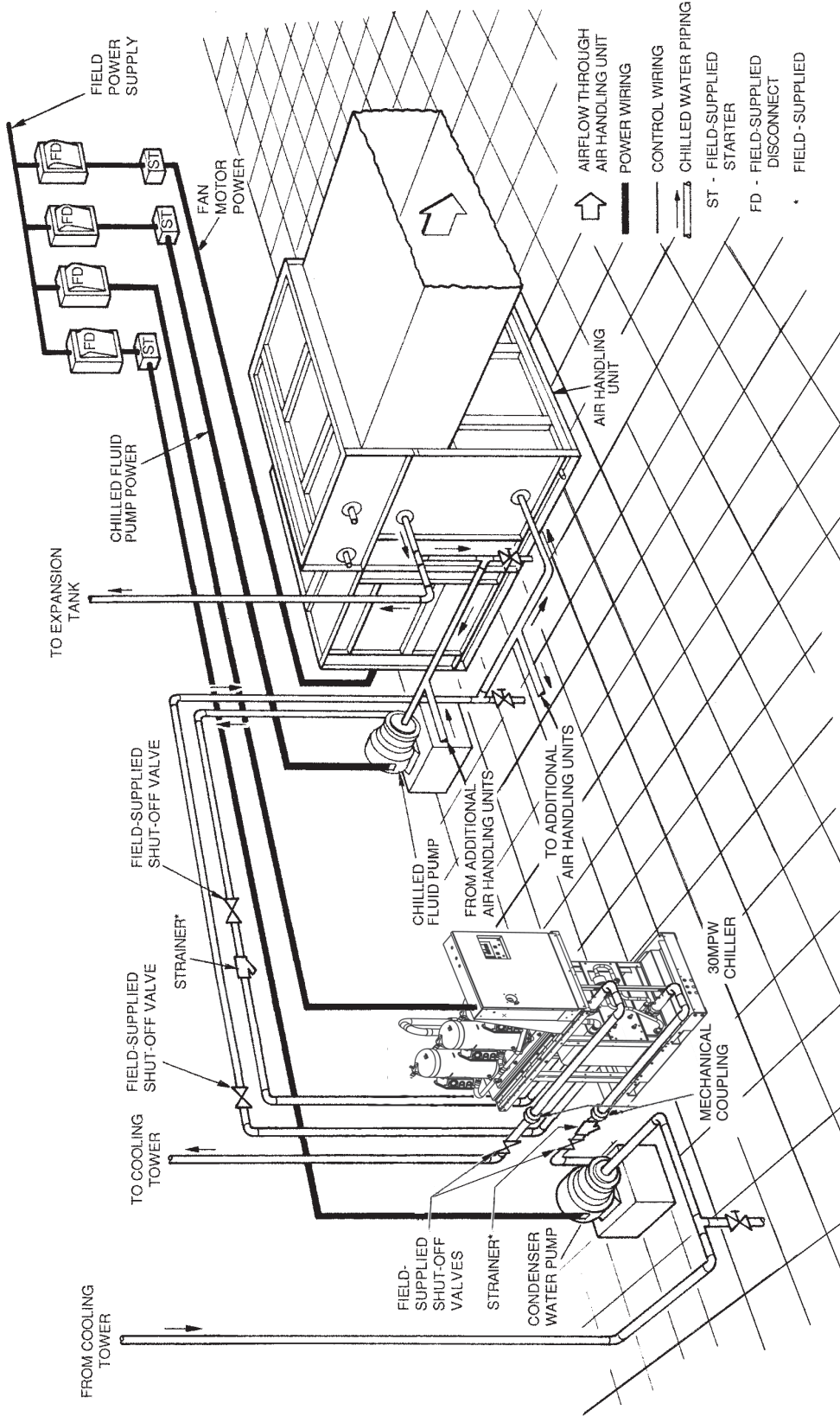

**NOTES:**

1. Chiller must be installed level to maintain proper compressor oil return.
2. Wiring and piping shown are general points-of-connection guides only and are not intended for a specific installation. Wiring and piping shown are for a quick overview of system and are not in accordance with recognized standards. Units should be installed using certified drawings.
3. All wiring must comply with applicable local and national codes.
4. All piping must follow standard piping techniques. Refer to Carrier System Design Manual or appropriate ASHRAE (American Society of Heating, Refrigerating, and Air Conditioning Engineers) handbook for details.
5. See Tables 1A and 1B for minimum system fluid volume. This system may require the addition of a holding tank to ensure adequate volume.
6. A strainer with a minimum of 40 mesh must be installed within 10 ft (3 m) of the evaporator fluid inlet to prevent debris from clogging or damaging the heat exchanger. This strainer is required and is available as an accessory.
7. Piping, wiring, switches, vents, strainers, drains, and vibration isolation are all field-supplied.

**Fig. 8 — Typical Piping with Liquid-Cooled 30MPW Chiller**



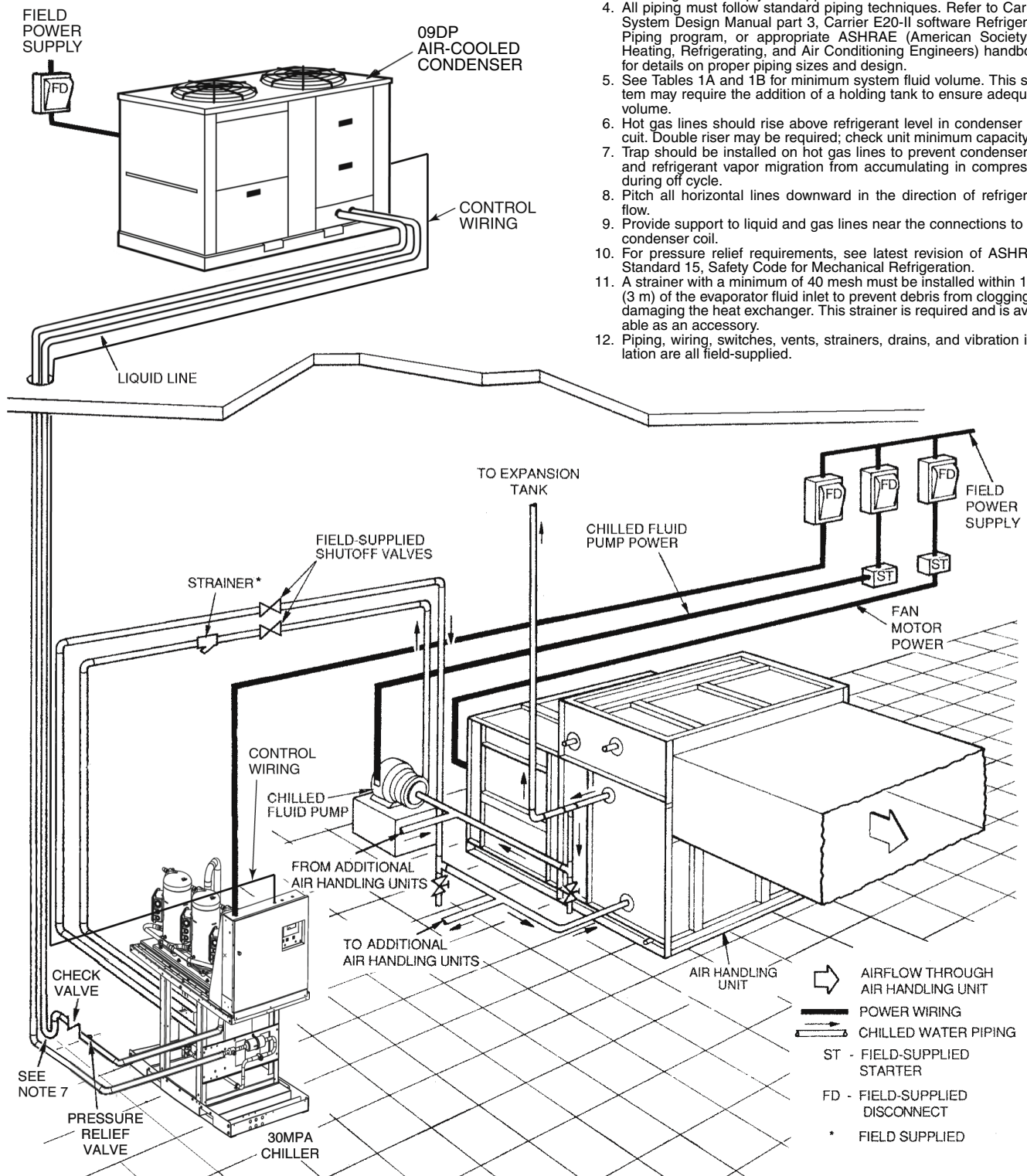

**NOTES:**

1. Chiller must be installed level to maintain proper compressor oil return.
2. Wiring and piping shown are general points-of-connection guides only and are not intended for a specific installation. Wiring and piping shown are for a quick overview of system and are not in accordance with recognized standards. Units should be installed using certified drawings.
3. All wiring must comply with applicable local and national codes.
4. All piping must follow standard piping techniques. Refer to Carrier System Design Manual part 3, Carrier E20-II software Refrigerant Piping program, or appropriate ASHRAE (American Society of Heating, Refrigerating, and Air Conditioning Engineers) handbook for details on proper piping sizes and design.
5. See Tables 1A and 1B for minimum system fluid volume. This system may require the addition of a holding tank to ensure adequate volume.
6. Hot gas lines should rise above refrigerant level in condenser circuit. Double riser may be required; check unit minimum capacity.
7. Trap should be installed on hot gas lines to prevent condenser oil and refrigerant vapor migration from accumulating in compressor during off cycle.
8. Pitch all horizontal lines downward in the direction of refrigerant flow.
9. Provide support to liquid and gas lines near the connections to the condenser coil.
10. For pressure relief requirements, see latest revision of ASHRAE Standard 15, Safety Code for Mechanical Refrigeration.
11. A strainer with a minimum of 40 mesh must be installed within 10 ft (3 m) of the evaporator fluid inlet to prevent debris from clogging or damaging the heat exchanger. This strainer is required and is available as an accessory.
12. Piping, wiring, switches, vents, strainers, drains, and vibration isolation are all field-supplied.

**Fig. 9 — Typical Piping with 30MPA Unit and 09DP Remote Air-Cooled Condenser**

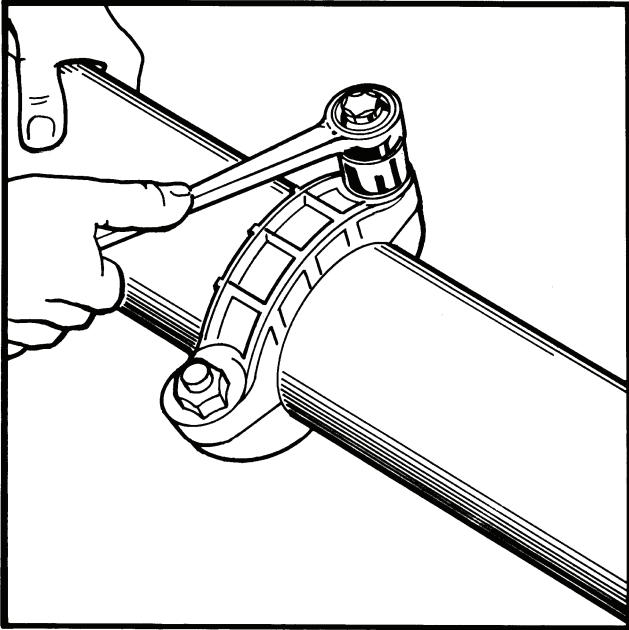

**Fig. 10 — Install the Victualic Coupling**

3. Install the inside coupling half over the gasket and then install the outer half. Connect with nuts and bolts. Tighten the nuts equally on both sides. Ensure there is no gap between the two halves of the coupling.
4. Alternately tighten the nuts with a wrench to draw the coupling halves together uniformly. The joint is now complete.

**30MPW UNITS** — In order to minimize the water pressure drop in the system, use as few bends as possible in the field water piping, and run the lines as short as possible. Size the water lines according to the available pump pressure (not necessarily the connection size), especially on cooling tower applications. See Carrier System Design Manual, Part 3, Piping Design. See Fig. 11 for condenser pressure drops.

Set water regulating valve, if installed, to maintain design head pressure. Do not adjust to compensate for high head pressures caused by fouled condensers, excess refrigerant, or the presence of noncondensables. Due to changes in water temperature, it may be necessary to adjust the valve seasonally. After adjusting for design head pressure, shut unit down. The water regulating valve should shut off the flow of water in a few minutes. If it does not, raise head pressure setting. Make sure that the capillary tube from each water regulating valve is connected to the proper condenser access fitting.

Provide a means for draining the system in the winter (if not used) and for maintenance.

Water leaving the condenser is under pressure and should not be connected directly into sewer lines. Check local codes.

**EVAPORATOR DESCRIPTION** — All 30MP units use a brazed-plate heat-exchanger type evaporator. The heat exchanger is constructed essentially the same as the brazed-plate condenser used on 30MPW units. See 30MPW Condenser Description section on page 7 for more details. Similar to the condenser, the evaporator can only be chemically cleaned. See Fig. 12 for evaporator pressure drops.

**EVAPORATOR PIPING** — Plan evaporator fluid piping for minimum number of changes in elevation, and for the fewest number of bends possible. Install manual or automatic vent valve at high points in the line. Maintain system pressure by using a pressure tank or a combination of relief and reducing valves.

A strainer with a minimum of 40 mesh **must** be installed within 10 ft of the evaporator fluid inlet to prevent debris from clogging or damaging the heat exchanger. This strainer is required and is available as an accessory.

See Carrier System Design Manual, Part 3, Piping Design, for chilled fluid piping details.

The evaporator fluid inlet and outlet connections are victualic. The fluid enters at the top connection and leaves at the bottom connection. Procedures for making the connections are the same as for the 30MPW condensers. See 30MPW Condenser section on page 7 for more details.

Run the pump for 10 minutes, then clean the strainer before starting the unit.

An evaporator flow switch is standard on all units. This is a thermal dispersion type switch that is installed in the evaporator fluid outlet. The switch is set to open when the evaporator fluid flow drops below the minimum set point.

For variable primary flow applications, it may be necessary to adjust the flow switch set point to avoid nuisance trips. Contact Carrier service engineering for the method needed to adjust the switch.

See Table 1 for minimum flow rates and loop volume.

The thermistors used to sense entering and leaving fluid temperature are factory-installed in the evaporator entering and leaving fluid nozzles.

**AIR SEPARATION** — For proper system operation, it is essential that water loops be installed with proper means to manage air in the system. Free air in the system can cause noise, reduce terminal output, stop flow, or even cause pump failure due to pump cavitation. For closed systems, equipment should be provided to eliminate all air from the system.

The amount of air that water can hold in solution depends on the pressure and temperature of the water/air mixture. Air is less soluble at higher temperatures and at lower pressures. Therefore, separation can best be done at the point of highest water temperature and lowest pressure. Typically, this point would be on the suction side of the pump as the water is returning from the system or terminals. Generally speaking, this is the best place to install an air separator, if possible.

1. Install automatic air vents at all high points in the system. (If the 30MP unit is located at the high point of the system, a vent can be installed on the piping entering the heat exchanger on the 1/4-in. NPT female port.)
2. Install an air separator in the water loop, at the place where the water is at higher temperatures and lower pressures — usually in the chilled water return piping. On a primary-secondary system, the highest temperature water is normally in the secondary loop, close to the decoupler. Preference should be given to that point on the system (see Fig. 13). In-line or centrifugal air separators are readily available in the field.

It may not be possible to install air separators at the place of lowest pressure and highest temperature. In such cases, preference should be given to the points of highest temperature. It is important that pipe be sized correctly so that free air can be moved to the point of separation. Generally, a water velocity of at least 2 feet per second will keep free air entrained and prevent it from forming air pockets.

Automatic vents should be installed at all physically elevated points in the system so that air can be eliminated during system operation. Provision should also be made for manual venting during the water loop fill. It is important that the automatic vents be located in accessible locations for maintenance purposes, and that they be located where they can be prevented from freezing.

ENGLISH

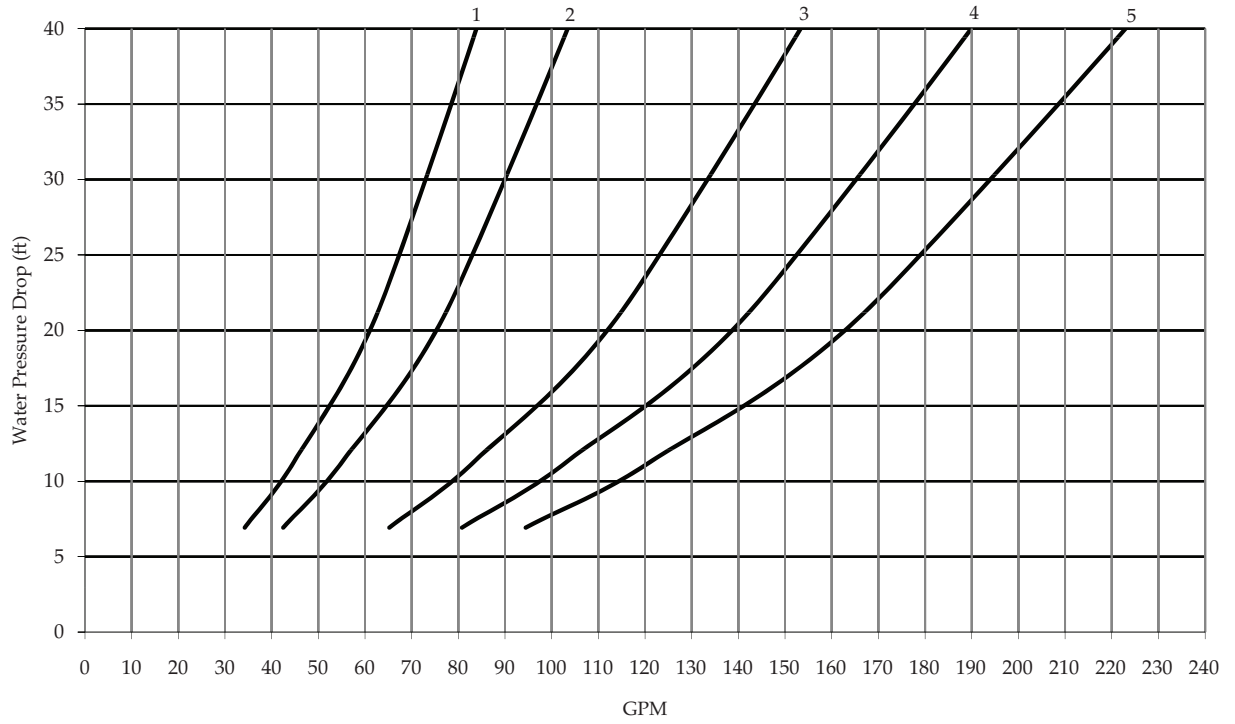

SI

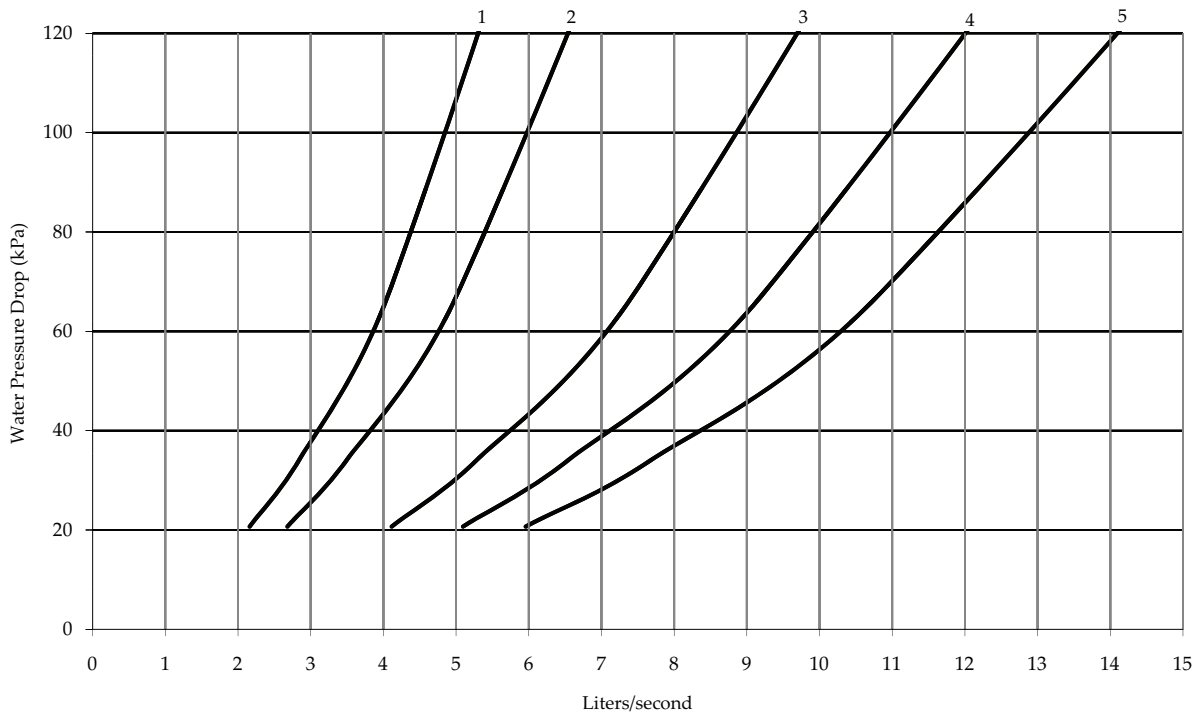

LEGEND

- 1 — 30MP015
- 2 — 30MP020
- 3 — 30MP030
- 4 — 30MP040
- 5 — 30MP045

Fig. 11 — Condenser Water Pressure Drop

ENGLISH

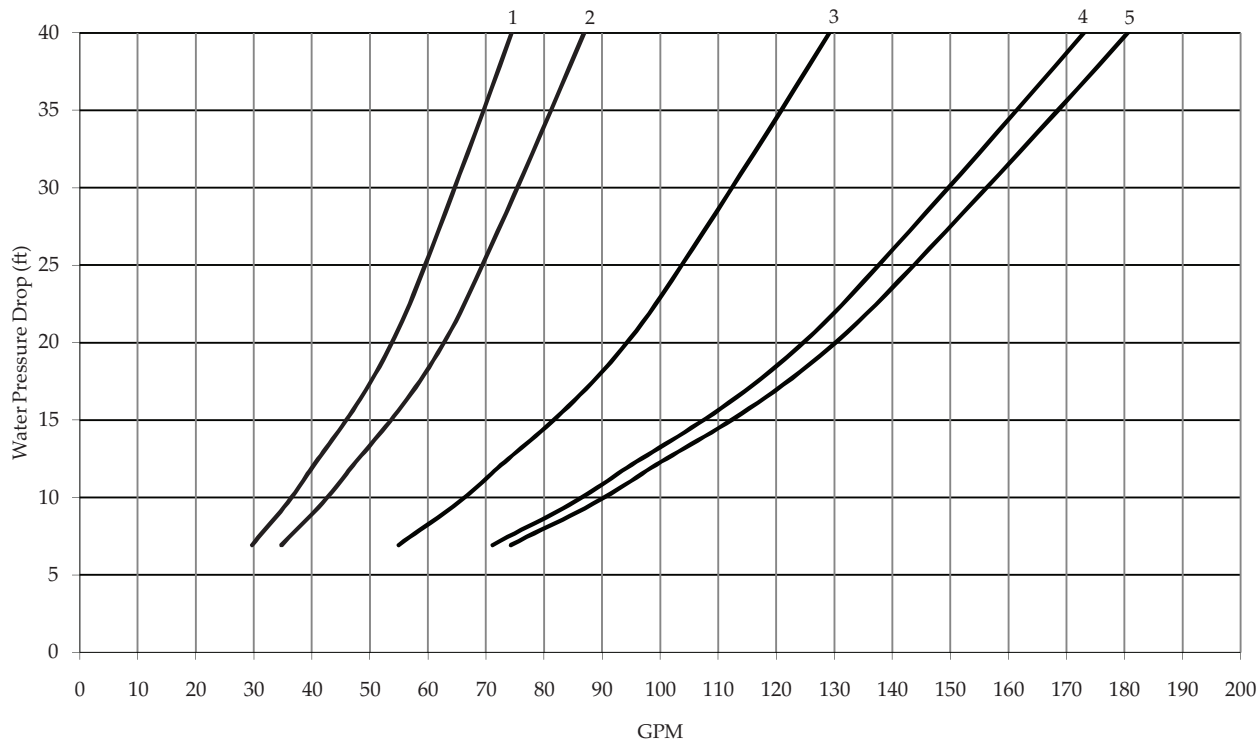

SI

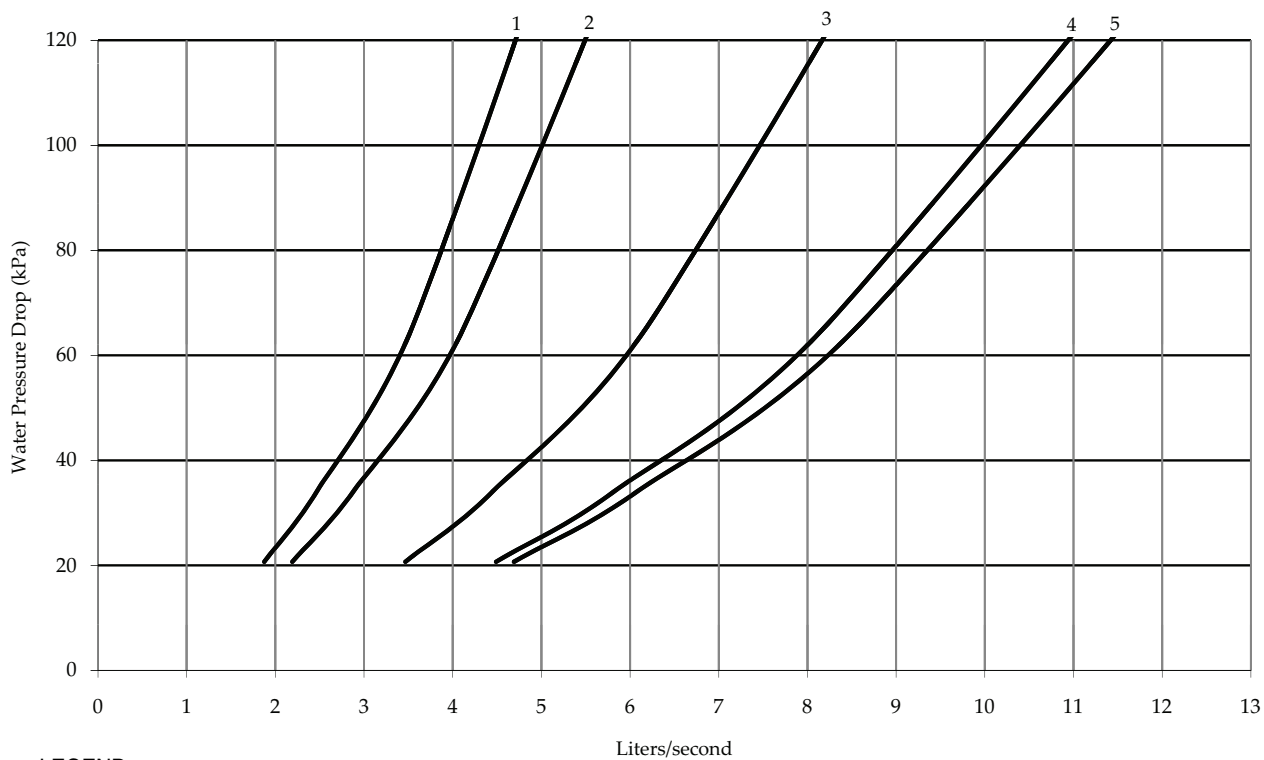

LEGEND

- 1 — 30MP015
- 2 — 30MP020
- 3 — 30MP030
- 4 — 30MP040
- 5 — 30MP045

Fig. 12 — Evaporator Water Pressure Drop

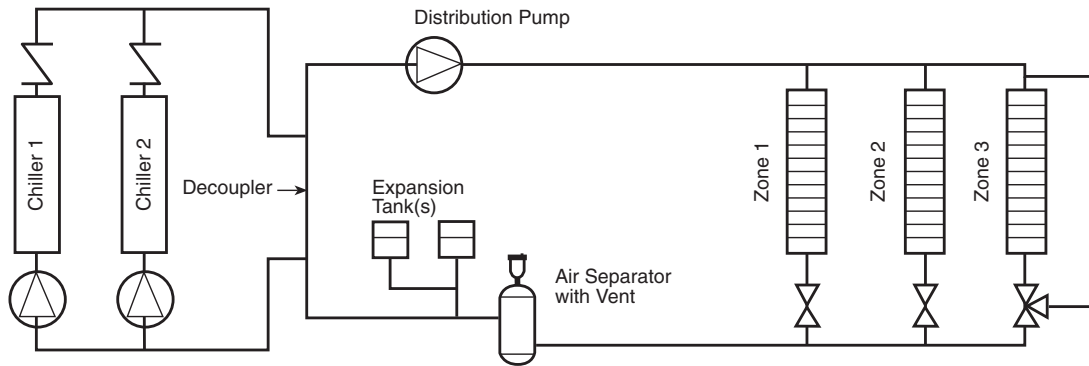

NOTE: Expansion tanks must be disconnected for chillers placed parallel in the primary water loop.

**Fig. 13 — Typical Air Separator and Expansion Tank Location on Primary-Secondary Systems**

### Step 6 — Fill the Chilled Water Loop

**WATER SYSTEM CLEANING** — Proper water system cleaning is of vital importance. Excessive particulates in the water system can cause excessive pump seal wear, reduce or stop flow, and cause damage of other components. Water quality should be maintained within the limits indicated in Table 2. Failure to maintain proper water quality may result in heat exchanger failure.

#### ⚠ CAUTION

Failure to properly clean all piping and components of the chilled water system before unit start-up may result in plugging of the heat exchanger, which can lead to poor performance, nuisance alarms and damage from freezing. Freezing damage caused by an improperly cleaned system represents abuse and may impair or otherwise negatively affect the Carrier product warranty.

1. Install a temporary bypass around the chiller to avoid circulating dirty water and particulates into the pump package and chiller during the flush. Use a temporary circulating pump during the cleaning process. Also, be sure that there is capability to fully drain the system after cleaning. (See Fig 14.)
2. Be sure to use a cleaning agent that is compatible with all system materials. Be especially careful if the system contains any galvanized or aluminum components. Both detergent-dispersant and alkaline-dispersant cleaning agents are available.
3. It is a good idea to fill the system through a water meter. This provides a reference point for the future for loop volume readings, but it also establishes the correct quantity of cleaner needed in order to get the required concentration.
4. Use a feeder/transfer pump to mix the solution and fill the system. Circulate the cleaning system for the length of time recommended by the cleaning agent manufacturer.
  - a. After cleaning, drain the cleaning fluid and flush the system with fresh water.
  - b. A slight amount of cleaning residue in the system can help keep the desired, slightly alkaline, water pH of 8 to 9. Avoid a pH greater than 10, since this will adversely affect pump seal components.
  - c. A side stream filter is recommended (see Fig. 15) during the cleaning process. Filter side flow rate should be enough to filter the entire water volume every 3 to 4 hours. Change filters as often as necessary during the cleaning process.

- d. Remove temporary bypass when cleaning is complete.

**Table 2 — Water Quality Characteristics and Limitations**

WATER CHARACTERISTIC	QUALITY LIMITATION
Alkalinity (HCO <sub>3</sub> <sup>-</sup> )	70 – 300 ppm
Sulfate (SO <sub>4</sub> <sup>2-</sup> )	Less than 70 ppm
HCO <sub>3</sub> <sup>-</sup> /SO <sub>4</sub> <sup>2-</sup>	Greater than 1.0
Electrical Conductivity	10 – 500 µS/cm
pH	7.5 – 9.0
Ammonium (NH <sub>3</sub> )	Less than 2 ppm
Chlorides (Cl <sup>-</sup> )	Less than 300 ppm
Free chlorine (Cl <sub>2</sub> )	Less than 1 ppm
Hydrogen Sulfide (H <sub>2</sub> S)*	Less than 0.05 ppm
Free (aggressive) Carbon Dioxide (CO <sub>2</sub> )†	Less than 5 ppm
Total Hardness (dH)	4.0 – 8.5
Nitrate (NO <sub>3</sub> )	Less than 100 ppm
Iron (Fe)	Less than 0.2 ppm
Aluminum (Al)	Less than 0.2 ppm
Manganese (Mn)	Less than 0.1 ppm

\*Sulfides in the water quickly oxidize when exposed to air, requiring that no agitation occur as the sample is taken. Unless tested immediately at the site, the sample will require stabilization with a few drops of one Molar zinc acetate solution, allowing accurate sulfide determination up to 24 hours after sampling. A low pH and high alkalinity cause system problems, even when both values are within the ranges shown. The term pH refers to the acidity, basicity, or neutrality of the water supply. Below 7.0, the water is considered to be acidic. Above 7.0, water is considered to be basic. Neutral water contains a pH of 7.0.

†Dissolved carbon dioxide can either be calculated from the pH and total alkalinity values, shown below, or measured on the site using a test kit. Dissolved Carbon Dioxide, PPM = TA × 2<sup>[(6.3-pH)/0.3]</sup> where TA = Total Alkalinity, PPM as CaCO<sub>3</sub>.

**FILLING THE SYSTEM** — The initial fill of the chilled water system must accomplish three purposes:

1. The entire piping system must be filled with water.
2. The pressure at the top of the system must be high enough to vent air from the system (usually 4 psig is adequate for most vents).
3. The pressure at all points in the system must be high enough to prevent flashing in the piping or cavitation in the pump.

The pressure created by an operating pump affects system pressure at all points except one — the connection of the compression tank to the system. This is the only location in the system where pump operation will not give erroneous pressure indications during the fill. Therefore, the best location to install the fill connection is close to the expansion tank. An air vent should be installed close by to help eliminate air that enters during the fill procedure.



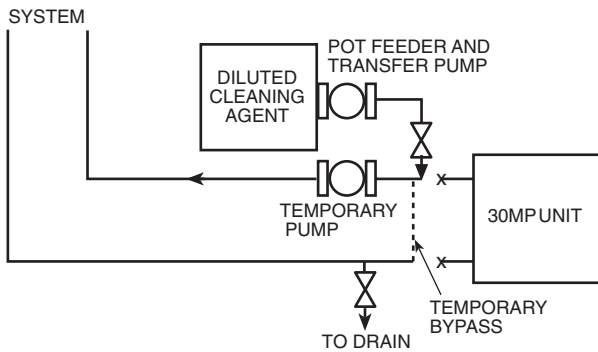

**Fig. 14 — Typical Set Up for Cleaning Process**

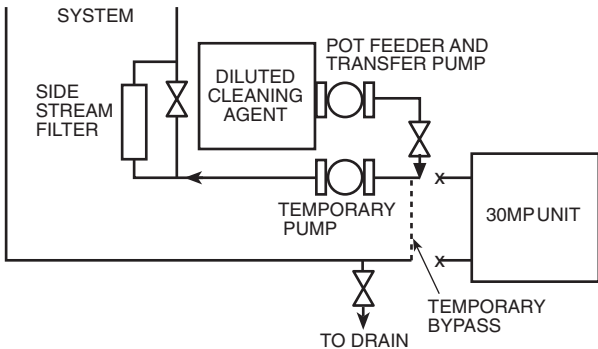

**Fig. 15 — Cleaning Using a Side Stream Filter**

Ensure the following when filling the system:

1. Remove temporary bypass piping and cleaning/flushing equipment.
2. Check to make sure all drain plugs are installed.
3. Open the blow-down valve to flush the strainer.

Normally, a closed system needs to be filled only once. The actual filling process is generally a fairly simple procedure. All air should be purged or vented from the system. Thorough venting at the high points and circulation at room temperature for several hours is recommended.

**NOTE:** Local codes concerning backflow devices and other protection of the city water system should be consulted and followed to prevent contamination of the public water supply. This is especially important when antifreeze is used in the system.

**Set Water Flow Rate** — Once the system is cleaned, pressurized, and filled, the flow rate through the chiller needs to be established.

**NOTE:** Carrier recommends a differential pressure gage when measuring pressures across the pumps or balancing valves. This provides for greater accuracy and reduces error build-up that often occurs when subtracting pressures made by different gages.

On primary/secondary systems, it is advisable to set the 30MP balancing valve to maintain design flow plus 10% through the chiller.

A rough estimate of water flow can also be obtained from measuring the pressure drop across the 30MP heat exchanger. Figures 11 and 12 show the relationship between gpm and heat exchanger pressure drop. It should be noted that these curves are for “clean” heat exchangers; they do not apply to heat exchangers with fouling. Adjust the external balancing valve until the correct pressure drop is obtained for the required gpm.

**Step 7 — Make Electrical Connections** — All field wiring must comply with local code requirements. Electrical data for the complete unit and for the compressors is shown in Table 3. See Fig. 16 for field wiring connections. A field-supplied branch circuit disconnect switch that can be locked in either OPEN or OFF position **must** be installed.

Control circuit power is 24 v on all units. Factory-installed control transformer (TRAN 1) uses line voltage for all units. All control transformers are factory-installed and wired. For 208/230-3-60 units operating at 208-3-60 line voltage, TRAN1 primary connections must be moved to terminals H3 and H4.

Inside the control box are terminals for field power and ground (earth) wiring. A ground wire must be installed with each field power supply. Compressors are wired for across-the-line start. Refer to Table 3 for electrical data.

**FLOW SWITCH** — A condenser flow switch is available as an accessory for all 30MPW units, and can be field-installed. The Carrier flow switch accessory (part no. 30MP-900--004) is available for this purpose. Flow switch wiring terminals are located in the field wiring compartment of the control box. The flow switch should be wired between terminals LVT-16 and LVT-17 for all units.

**CONTROL BOX, POWER SECTION** — The electrical power supply is brought in through the top left-hand side of the control box. Pressure-lug connections on the terminal blocks are suitable for only for copper conductors.

The control box power section contains the following components:

- power terminal block
- optional disconnect switch
- compressor circuit breaker(s)
- compressor contactor(s)
- current sensor boards
- control transformer
- ground lug
- neutral terminal (380-3-60 units only)
- crankcase heater relay (30MPA units only)
- fuses

**CONTROL BOX, CONTROLS SECTION** — The control box controls section contains the following components:

- main base board (MBB)
- scrolling marquee display
- optional energy management module
- control-circuit breakers for 24-v circuits
- control-circuit ON-OFF switch
- unit Enable/Off/Remote contact switch
- unit Alarm/Alert indicator light

**CONTROL BOX, FIELD CONTROL WIRING SECTION** — Inside this section is the low-voltage, field-wiring terminal strip (LVT). All low-voltage field-wiring connections are made to this terminal block. There are three 7/8-in. (22 mm) knockouts provided for field wiring in this section. Connections for condenser flow switch, chilled fluid pump interlock, condenser pump interlock, remote alarm output, condenser output, and dual chiller thermistor accessory are made at these locations. See Fig. 16 for specific location of connections.

The unit has the capability to control field-supplied devices. They are: alarm signal, condenser pump or condenser fan output, and chilled water pump output. The unit provide 24-v power with a minimum 5 va rating per output allowed.

**UNBALANCED 3-PHASE SUPPLY VOLTAGE** — *Never operate a compressor where a phase imbalance in the supply voltage is greater than 2%.* Use the following formula to determine the percent voltage imbalance:

$$\% \text{ Voltage Imbalance} = 100 \times \frac{\text{max voltage deviation from average voltage}}{\text{average voltage}}$$



EXAMPLE: Supply voltage is 240-3-60.

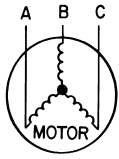

AB = 243 v  
BC = 236 v  
AC = 238 v

$$\text{Average Voltage} = \frac{243 + 236 + 238}{3} = 239 \text{ v}$$

Determine maximum deviation from average voltage:

(AB)  $243 - 239 = 4 \text{ v}$

(BC)  $239 - 236 = 3 \text{ v}$

(AC)  $239 - 238 = 1 \text{ v}$

Maximum deviation is 4 v.

Determine percent voltage imbalance:

$$\% \text{ Voltage Imbalance} = 100 \times \frac{4}{239} = 1.7\%$$

This amount of phase imbalance is satisfactory as it is below the maximum allowable 2%.

**IMPORTANT:** If the supply voltage phase imbalance is more than 2%, contact your local utility company immediately.

**Table 3 — Electrical Data — 30MPA,MPW Units**

UNIT SIZE 30MPA,MPW	VOLTS NAMEPLATE (3 ph, 60 Hz)	VOLTAGE*		COMPRESSOR		UNIT			
		Min	Max	Quantity	LRA (ea.)	MCA	ICF	MOCP	Rec Fuse
015	208/230	187	253	2	195	66.4	224.5	90	80
	380	342	418		123	37.6	139.7	50	45
	460	414	508		95	33.1	109.7	45	40
	575	518	632		80	27.5	92.2	35	35
020	208/230	187	253	2	239	80.6	274.8	110	90
	380	342	418		145	53.4	168.7	70	60
	460	414	508		125	40.3	142.9	50	45
	575	518	632		80	32.2	94.3	45	40
030	208/230	187	253	2	340	125.6	395.8	175	150
	380	342	418		196	76.5	230.0	110	90
	460	414	508		179	60.5	205.9	80	70
	575	518	632		132	53.3	155.7	70	60
040	208/230	187	253	3	300	166.7	402.6	200	200
	380	342	418		139	87.4	192.8	110	100
	460	414	508		150	75.1	196.2	90	90
	575	518	632		109	64.7	148.8	80	70
045	208/230	187	253	3	340	181.4	451.6	225	200
	380	342	418		196	110.5	264.0	125	125
	460	414	508		179	87.4	232.8	110	100
	575	518	632		132	77.0	179.4	100	90

**LEGEND**

- ICF** — Maximum instantaneous current flow during starting.
- kcmil** — Thousand circular mils
- LRA** — Locked rotor amps.
- MCA** — Minimum circuit amps (for wire sizing). Complies with NEC, Section 430-24.
- MOCP** — Maximum Overcurrent Protection
- NEC** — National Electrical Code (U.S.A.)
- Rec Fuse** — Recommended dual element fuse amps (150% of compressor RLA). Size up to the next standard fuse size.

\*Supply Range — Units are suitable for use on electrical systems where voltage supplied to the unit terminals is not below or above the listed range limits.

**NOTES:**

1. All units have one field power terminal block.
2. Maximum incoming wire size is as follows:  
For units with terminal block:  
350 kcmil for unit sizes 030-045; 208/230-3-60 voltages.  
2/0 for all other unit sizes; all voltages.  
For units with optional non-fused disconnect:  
350 kcmil for unit sizes:  
030-045; 208/230-3-60 voltages.  
045; 380-3-60 voltage.

3/0 for unit sizes:

- 015,020; 208/230-3-60 voltages.
- 020-040; 380-3-60 voltage.
- 030-045; 460-3-60 and 575-3-60 voltages.

2 AWG for unit sizes:

- 015; 380-3-60 voltage.
- 015-020; 460-3-60 and 575-3-60 voltages.

3. Additional control circuit power is not required.
4. Any field modification of factory wiring must be in compliance with all applicable codes. Field-installed power wires must be rated 75 C minimum.
5. Use copper conductors only.
6. Control circuit power supply is 24-v single phase. Control power is supplied by the factory-installed control transformer.



<b>LEGEND</b>	Alarm Relay (24 V) 5 VA Max
—	American Wire Gage
—	Condenser Fan Relay
—	Condenser Flow Switch
—	Condenser Pump
—	Condenser Pump Interlock
—	Chilled Water Pump
—	Chilled Water Pump Interlock
—	Condenser Water Valve
—	Energy Management Module
—	Low Voltage Terminal Strip
—	National Electrical Code
—	Outside Air Temperature
—	Space Temperature

<b>ALMR</b>	Alarm Relay (24 V) 5 VA Max
<b>AWG</b>	American Wire Gage
<b>CFR</b>	Condenser Fan Relay
<b>CNFS</b>	Condenser Flow Switch
<b>CNP</b>	Condenser Pump
<b>CNPI</b>	Condenser Pump Interlock
<b>CWPI</b>	Chilled Water Pump
<b>CWV</b>	Chilled Water Pump Interlock
<b>EMM</b>	Energy Management Module
<b>LVT</b>	Low Voltage Terminal Strip
<b>NEC</b>	National Electrical Code
<b>OAT</b>	Outside Air Temperature
<b>SPT</b>	Space Temperature

- NOTES:**
- Factory wiring is in accordance with UL 1995 standards. Field modifications or additions must be in compliance with all applicable codes.
  - All units or modules have single point primary power connection. Main power must be supplied from a field or factory supplied disconnect.
  - Wiring for main field supply must be rated 75 C. Use copper conductors only.
    - Incoming wire size range for terminal block with MCA up to 120 amps is 14 AWG (American Wire Gage) to 2/0.
    - Incoming wire size range for terminal block with MCA from 120.1 amps to 310 amps is 6 AWG to 350 kcmil.
    - Incoming wire size range for non-fused disconnect with MCA up to 50 amps is 10 AWG to 2 AWG.
    - Incoming wire size range for non-fused disconnect with MCA from 50.1 amps to 90 amps is 6 AWG to 3/0.
    - Incoming wire size range for non-fused disconnect with MCA from 90.1 amps to 250 amps is 4 AWG to 350 kcmil.
  - Refer to certified dimensional drawings for exact locations of the main power and control power entrance locations.
  - Terminal 24 of the LVT is for control of chilled water pump (CWP) starter. Terminal 20 of the LVT is for control of condenser pump (CNP) starter or condenser fan relay (CFR). The maximum load allowed for the relays is 5 VA sealed. 10 VA inrush at 24 VAC. Field power supply is required.
  - Terminal 25 of LVT is for an alarm relay. The maximum load allowed for alarm relay is 5 VA sealed, 10 VA inrush at 24 VAC. Field power supply is not required.
  - Make appropriate connections to LVT as shown for energy management board options. The contacts for demand limit and ice done options must be rated for dry circuit application capable of handling 24 VAC load up to 50 mA. Installation of optional energy management board required. Remove jumper between terminals 16 and 17 when field chilled water pump interlock (CWP1) is installed.
  - Terminals 18 and 19 of LVT are for floating point control of condenser water valve (CWV). Terminal 18 commands valve closed. Terminal 19 commands valve open. The maximum load allowed for condenser water valve is 5.5 VA at 24 VAC. Field power supply is not required.
  - All discrete inputs are 24 VAC.

### LVT CONTROL WIRING

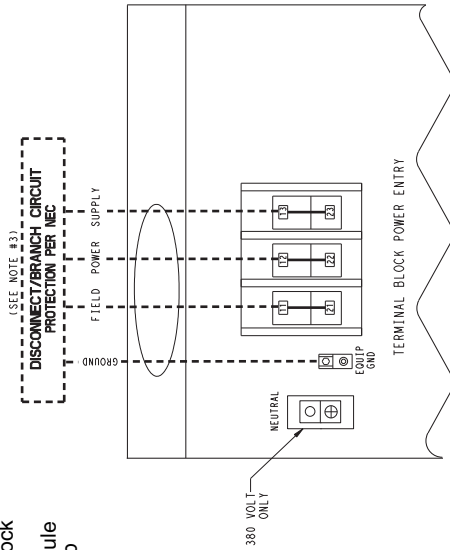
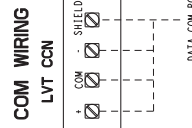
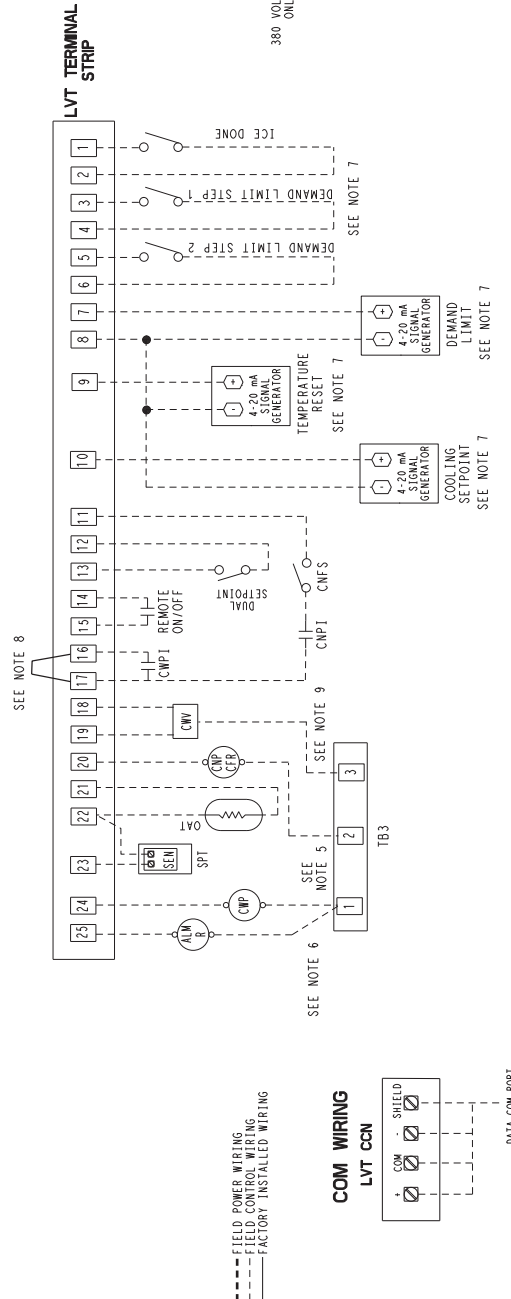

### TERMINAL BLOCK

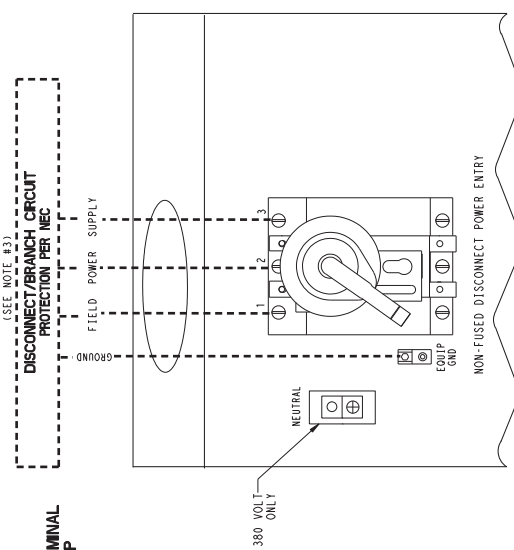

### NON-FUSED DISCONNECT

Fig. 16 — Typical Low Voltage Control Wiring